

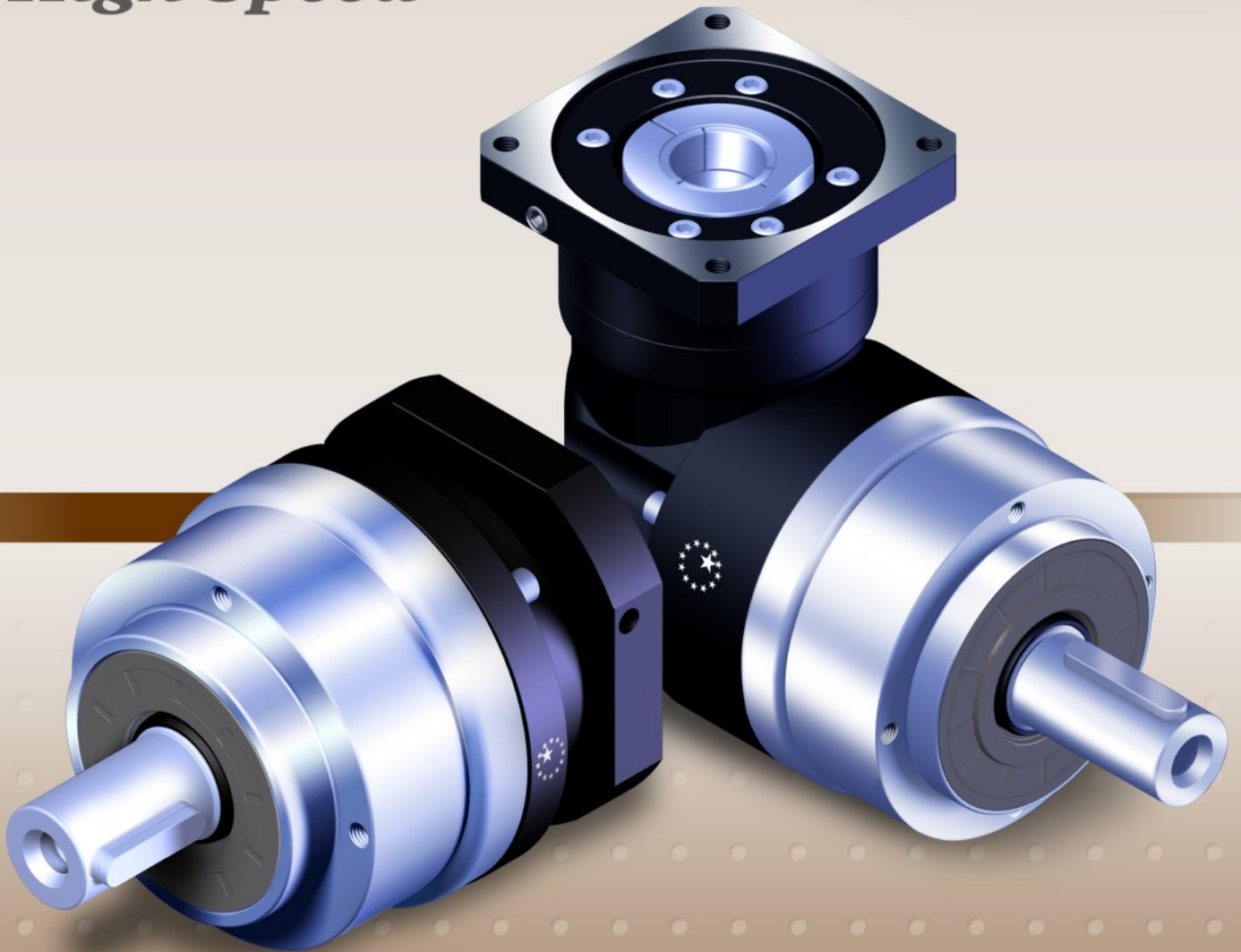

APEX DYNAMICS, INC.

AE / AER Series

*Planetary Gearboxes
High Precision
High Speed*



Stainless

AE / AER Series

Characteristic Highlights

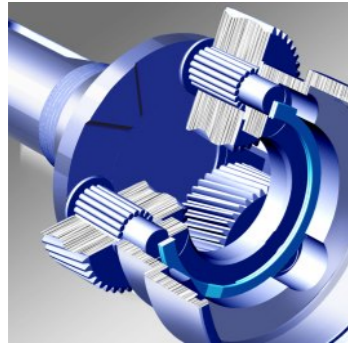

Equipped with **solid uncaged needle roller bearings**, provides maximum contact points to increase stiffness and transmit high output torque.

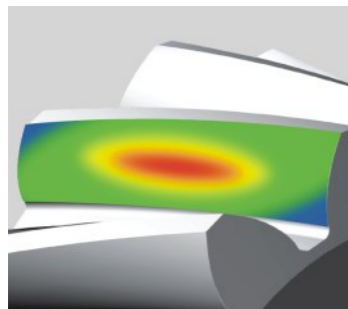

A high setting gear performance is achieved by using our **HeliTopo technology**. This **eases off the tooth profile** and **crowns the lead of each tooth**. This optimizes the gear mesh alignment and overlap to achieve maximum tooth surface contact.

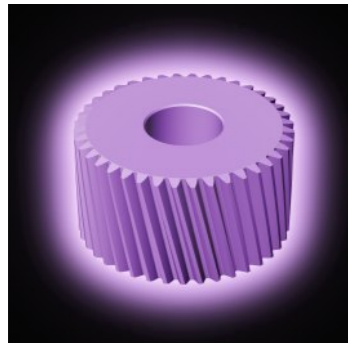

Our **in-house plasma nitriding** heat treatment process maintains the tooth surface hardness at **900Hv** for superior wear-resistance and a core hardness at **30 HRC** for toughness.

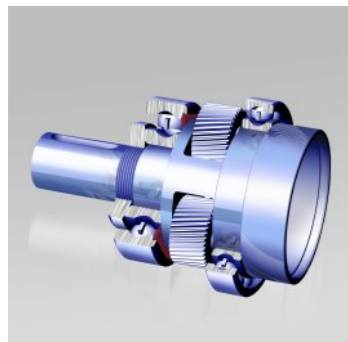

One piece planet carrier with extended bearing design provides maximum radial load capacity and increases system reliability and stiffness.



True helical gear design
Precision helical gearing increases tooth to tooth contact ratio by over 33% vs spur gearing. The helix angle produces smooth and quiet operation with decreased backlash (less than 8 arc-minutes and $\leq 56\text{dB}$).

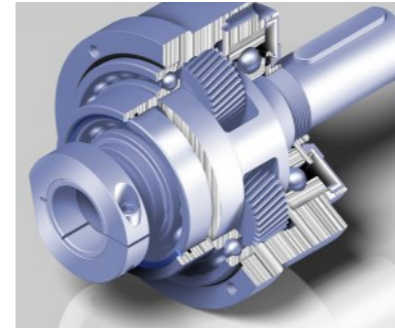

Patented planet carrier design puts the sun gear bearing directly into the planet carrier. It minimizes gear misalignment to gain higher accuracy.

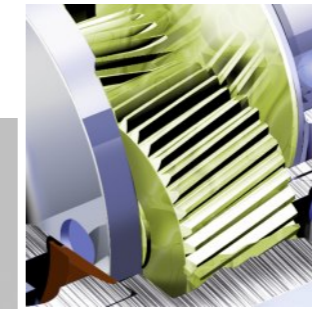

Triple split collet with dynamic balanced set collar clamping system provides backlash free power transmission and eliminates slippage. 100% concentricity allows for smooth rotation and higher input speed capability.

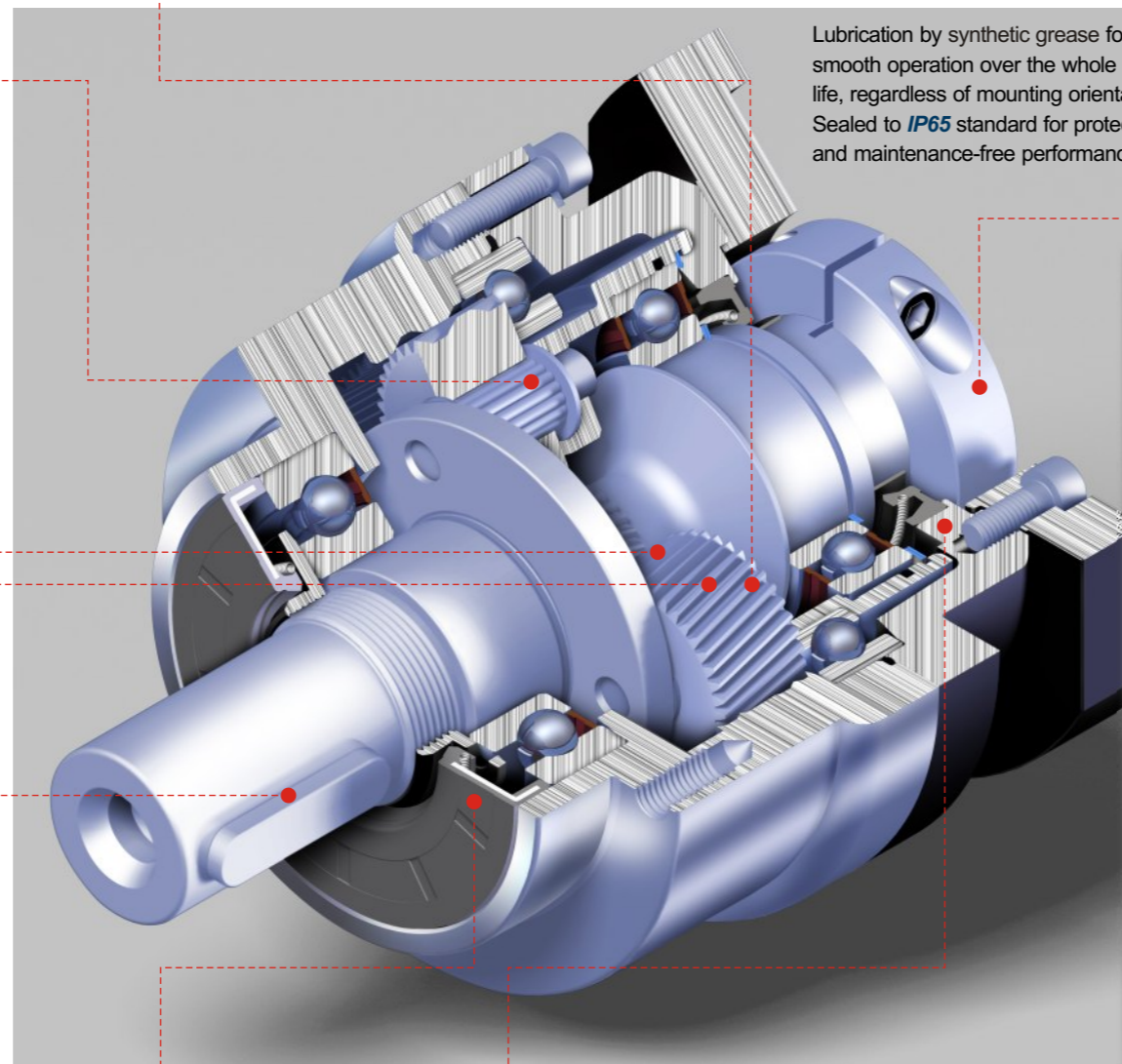

Lubrication by synthetic grease for smooth operation over the whole service life, regardless of mounting orientation. Sealed to **IP65** standard for protection and maintenance-free performance.

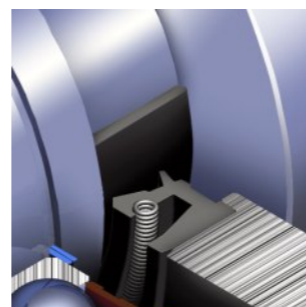
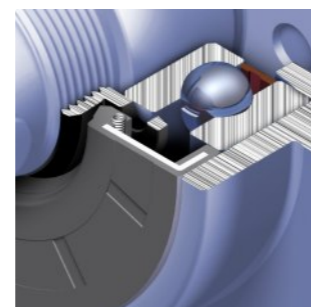

Patented sealing system featuring a TiCN coated shaft surface that eliminates leakage and increases service life to over 20,000 hours. The high tech coating, with a surface quality of $0.2\ \mu\text{m}$ and hardness of 3700 Hv. Interfaces with our proprietary seal, decreasing wear and running temperature.

AER Series

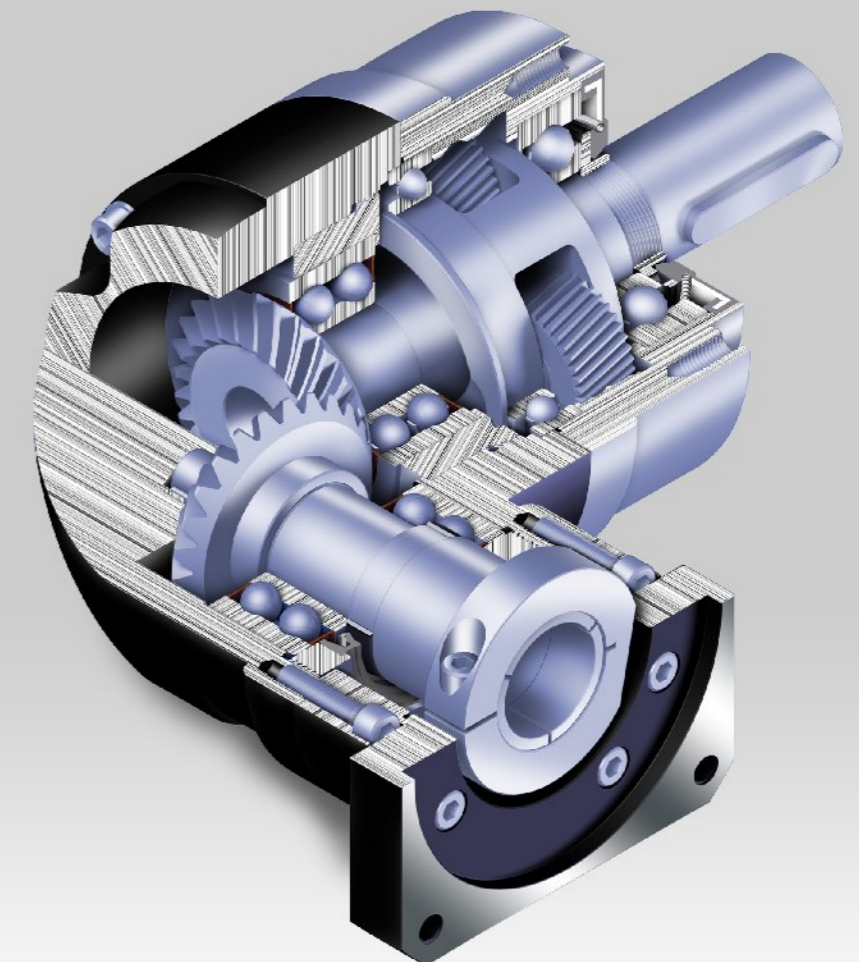

AER version with 90° input via helical bevel gear. Featuring an extremely short, light yet rigid housing and full compatibility with standard motor adapters.

AE Series

Specifications

Gearbox Performance

Model No.	Stage	Ratio ¹	AE050	AE070	AE090	AE120	AE155	AE205	AE235	
Nominal output torque T_{2N}	1	3	20	55	130	208	342	588	1,140	
		4	19	50	140	290	542	1,050	1,700	
		5	22	60	160	330	650	1,200	2,000	
		6	20	55	150	310	600	1,100	1,900	
		7	19	50	140	300	550	1,100	1,800	
		8	17	45	120	260	500	1,000	1,600	
		9	14	40	100	230	450	900	1,500	
		10	14	40	100	230	450	900	1,500	
		2	15	20	55	130	208	342	588	1,140
			20	19	50	140	290	542	1,050	1,700
	25		22	60	160	330	650	1,200	2,000	
	30		20	55	150	310	600	1,100	1,900	
	35		19	50	140	300	550	1,100	1,800	
	40		17	45	120	260	500	1,000	1,600	
	45		14	40	100	230	450	900	1,500	
	50		22	60	160	330	650	1,200	2,000	
	60		20	55	150	310	600	1,100	1,900	
	70		19	50	140	300	550	1,100	1,800	
	80	17	45	120	260	500	1,000	1,600		
	90	14	40	100	230	450	900	1,500		
100	14	40	100	230	450	900	1,500			
Emergency Stop Torque T_{2NOT} ²	Nm	1,2	3 times of nominal output torque							
Nominal input speed n_{1N}	rpm	1,2	3~100	5,000	5,000	4,000	4,000	3,000	3,000	2,000
Max. input speed n_{1B}	rpm	1,2	3~100	10,000	10,000	8,000	8,000	6,000	6,000	4,000
Backlash	arcmin	1	3~10	≤8	≤8	≤8	≤8	≤8	≤8	≤8
		2	15~100	≤12	≤12	≤12	≤12	≤12	≤12	≤12
Torsional rigidity	Nm/arcmin	1,2	3~100	3	7	14	25	50	145	225
Max. Radial Load F_{2rB} ³	N	1,2	3~100	702	1,377	2,985	6,100	8,460	13,050	8,700
Max. Axial Load F_{2aB} ³	N	1,2	3~100	390	765	1,625	3,350	4,700	7,250	18,000
Service life	hr	1,2	3~100	20,000*						
Efficiency η	%	1	3~10	≥97%						
		2	15~100	≥94%						
Weight	kg	1	3~10	0.6	1.4	3.3	6.9	13	31	53
		2	15~100	0.9	1.6	4.7	8.7	17	35	66
Operating temp	°C	1,2	3~100	-10°C~90°C						
Lubrication				Synthetic lubrication oils						
Degree of gearbox protection		1,2	3~100	IP65						
Mounting position		1,2	3~100	all directions						
Noise Level ($n_1=3000\text{rpm}$, No Load)	dB(A)	1,2	3~100	≤56	≤58	≤60	≤63	≤65	≤67	≤70

Gearbox Inertia

Model No.	Stage	Ratio ¹	AE050	AE070	AE090	AE120	AE155	AE205	AE235	
Mass moments of inertia J,	1	3	0.03	0.16	0.61	3.25	9.21	28.98	69.61	
		4	0.03	0.14	0.48	2.74	7.54	23.67	54.37	
		5	0.03	0.13	0.47	2.71	7.42	23.29	53.27	
		6	0.03	0.13	0.45	2.65	7.25	22.75	51.72	
		7	0.03	0.13	0.45	2.62	7.14	22.48	50.97	
		8	0.03	0.13	0.44	2.58	7.07	22.59	50.84	
		9	0.03	0.13	0.44	2.57	7.04	22.53	50.63	
		10	0.03	0.13	0.44	2.57	7.03	22.51	50.56	
		2	15	0.03	0.03	0.13	0.47	2.71	7.42	23.29
			20	0.03	0.03	0.13	0.47	2.71	7.42	23.29
	25		0.03	0.03	0.13	0.47	2.71	7.42	23.29	
	30		0.03	0.03	0.13	0.47	2.71	7.42	23.29	
	35		0.03	0.03	0.13	0.47	2.71	7.42	23.29	
	40		0.03	0.03	0.13	0.47	2.71	7.42	23.29	
	45		0.03	0.03	0.13	0.47	2.71	7.42	23.29	
	50		0.03	0.03	0.13	0.44	2.57	7.03	22.51	
	60		0.03	0.03	0.13	0.44	2.57	7.03	22.51	
	70		0.03	0.03	0.13	0.44	2.57	7.03	22.51	
	80	0.03	0.03	0.13	0.44	2.57	7.03	22.51		
	90	0.03	0.03	0.13	0.44	2.57	7.03	22.51		
100	0.03	0.03	0.13	0.44	2.57	7.03	22.51			

1. Ratio ($i=N_e/N_{out}$)

2. T_{2B} = 60% of T_{2NOT}

3. Applied to the output shaft center @ 100 rpm

★ S1 service life 10,000 hrs (Consult us)

Dimensions (1-stage, Ratio i=3~10)

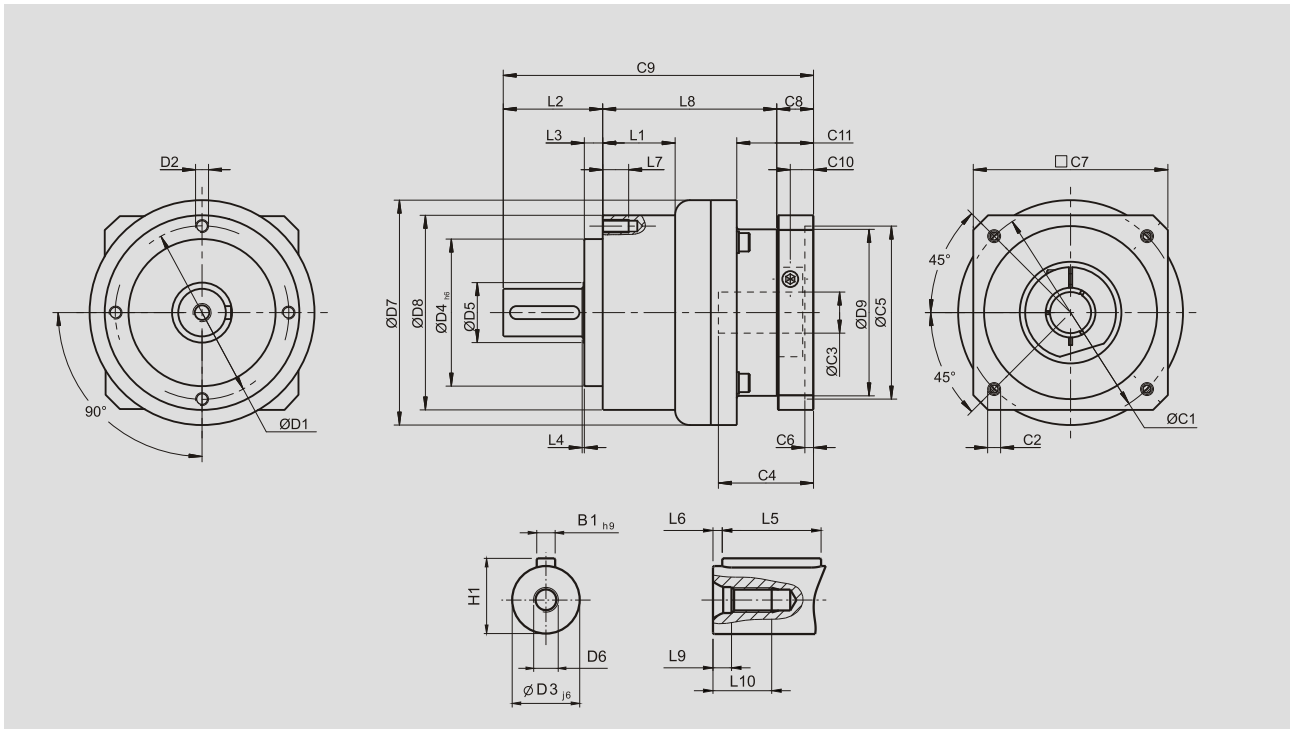

[unit: mm]

Dimension	AE050	AE070	AE090	AE120	AE155	AE205	AE235
D1	44	62	80	108	140	184	210
D2	M4 x 0.7P	M5 x 0.8P	M6 x 1P	M8 x 1.25P	M10 x 1.5P	M12 x 1.75P	M16 x 2P
D3 _{j6}	12	16	22	32	40	55	75
D4 _{h6}	35	52	68	90	120	160	180
D5	22	22	30	40	75	95	115
D6	M4 x 0.7P	M5 x 0.8P	M8 x 1.25P	M12 x 1.75P	M16 x 2P	M20 x 2.5P	M20 x 2.5P
D7	53	70	104	130	162	205	260
D8	50	70	90	120	155	205	235
D9	45.5	53.4	77	102	125	160	205
L1	--	--	33.5	38	50	--	70
L2	24.5	36	46	70	97	100	126
L3	4	6.5	8.5	17.5	15	15	18
L4	1	1	1	1.5	3	3	3
L5	14	25	32	40	63	70	90
L6	2	2	3	5	5	6	7
L7	8	10	12	16	20	22	28
L8	47	62	80.5	97	119.5	159	175.5
L9	4.5	4.8	7.2	10	12	15	15
L10	10	12.5	19	28	36	42	42
C1 ⁴	46	70	100	130	165	215	235
C2 ⁴	M4 x 0.7P	M5 x 0.8P	M6 x 1P	M8 x 1.25P	M10 x 1.5P	M12 x 1.75P	M12 x 1.75P
C3 ⁴	★ ≤11 / ≤12	★ ≤14 / ≤16	≤19 / ≤24	≤32	≤38	≤48	≤55
C4 ⁴	30	34	40	50	60	85	116
C5 ⁴	30	50	80	110	130	180	200
C6 ⁴	3.5	8	4	5	6	6	6
C7 ⁴	48	60	90	115	142	190	220
C8 ⁴	19.5	19	17	19.5	22.5	29	63
C9 ⁴	91	117	143.5	186.5	239	288	364.5
C10 ⁴	13.25	13.5	10.75	13	15	20.75	53.5
C11 ⁴	19.5	37	35.5	46	53.5	79.5	106.5
B1 _{h9}	4	5	6	10	12	16	20
H1	14	18	24.5	35	43	59	79.5

4. C1~C11 are motor specific dimensions (metric std shown). Refer to Apexdyna.com and Design Tool to view your specific motor mounting system.

★ AE050 ratio 5, 10 offers C3≤12 option. ★ AE070 ratio 5, 10 offers C3≤16 option.

AE Series

Dimensions (2-stage, Ratio $i=15\sim 100$)

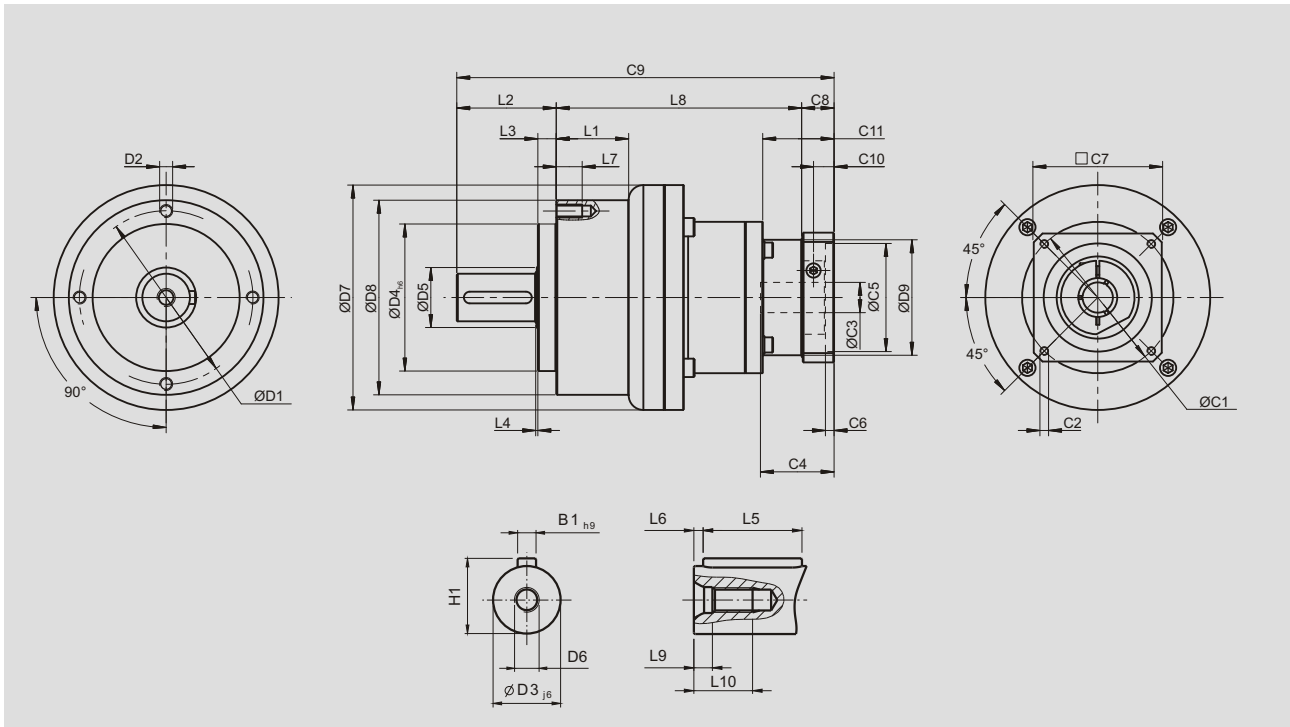

[unit: mm]

Dimension	AE050	AE070	AE090	AE120	AE155	AE205	AE235
D1	44	62	80	108	140	184	210
D2	M4 x 0.7P	M5 x 0.8P	M6 x 1P	M8 x 1.25P	M10 x 1.5P	M12 x 1.75P	M16 x 2P
D3 _{j6}	12	16	22	32	40	55	75
D4 _{h6}	35	52	68	90	120	160	180
D5	22	22	30	40	75	95	115
D6	M4 x 0.7P	M5 x 0.8P	M8 x 1.25P	M12 x 1.75P	M16 x 2P	M20 x 2.5P	M20 x 2.5P
D7	53	70	104	130	162	205	260
D8	50	70	90	120	155	205	235
D9	45.5	45.5	53.4	77	102	125	160
L1	--	--	33.5	38	50	--	70
L2	24.5	36	46	70	97	100	126
L3	4	6.5	8.5	17.5	15	15	18
L4	1	1	1	1.5	3	3	3
L5	14	25	32	40	63	70	90
L6	2	2	3	5	5	6	7
L7	8	10	12	16	20	22	28
L8	74	87.5	113.5	138.5	176	214.5	260
L9	4.5	4.8	7.2	10	12	15	15
L10	10	12.5	19	28	36	42	42
C1 ⁵	46	46	70	100	130	165	215
C2 ⁵	M4 x 0.7P	M4 x 0.7P	M5 x 0.8P	M6 x 1P	M8 x 1.25P	M10 x 1.5P	M12 x 1.75P
C3 ⁵	≤11 / ≤12	≤11 / ≤12	≤14 / ≤15.875 / ≤16	≤19 / ≤24	≤32	≤38	≤48
C4 ⁵	30	30	34	40	50	60	85
C5 ⁵	30	30	50	80	110	130	180
C6 ⁵	3.5	3.5	8	4	5	6	6
C7 ⁵	48	48	60	90	115	142	190
C8 ⁵	19.5	19.5	19	17	19.5	22.5	29
C9 ⁵	118	143	178.5	225.5	292.5	337	415
C10 ⁵	13.25	13.25	13.5	10.75	13	15	20.75
C11 ⁵	19.5	19.5	37	35.5	46	53.5	79.5
B1 _{h9}	4	5	6	10	12	16	20
H1	14	18	24.5	35	43	59	79.5

5. C1~C11 are motor specific dimensions (metric std shown). Refer to Apexdyna.com and Design Tool to view your specific motor mounting system.

AER Series

Specifications

Gearbox Performance

Model No.	Stage	Ratio	AER050	AER070	AER090	AER120	AER155	AER205	AER235	
Nominal output torque T_{2N}	1	3	9	36	90	195	342	588	1,140	
		4	12	48	120	260	520	1,040	1,680	
		5	15	60	150	325	650	1,200	2,000	
		6	18	55	150	310	600	1,100	1,900	
		7	19	50	140	300	550	1,100	1,800	
		8	17	45	120	260	500	1,000	1,600	
		9	14	40	100	230	450	900	1,500	
		10	14	40	100	230	450	900	1,500	
		14	-	42	140	300	550	1,100	1,800	
		20	-	40	100	230	450	900	1,500	
		2	15	14	-	-	-	-	-	-
			20	14	-	-	-	-	-	-
	25		15	60	150	325	650	1,200	2,000	
	30		20	55	150	310	600	1,100	1,900	
	35		19	50	140	300	550	1,100	1,800	
	40		17	45	120	260	500	1,000	1,600	
	45		14	40	100	230	450	900	1,500	
	50		14	60	100	230	650	1,200	2,000	
	60		20	55	150	310	600	1,100	1,900	
	70		19	50	140	300	550	1,100	1,800	
	80		17	45	120	260	500	1,000	1,600	
	90		14	40	100	230	450	900	1,500	
	100	14	40	100	230	450	900	1,500		
	120	-	-	150	310	600	1,100	1,900		
140	-	-	140	300	550	1,100	1,800			
160	-	-	120	260	550	1,000	1,600			
180	-	-	100	230	450	900	1,500			
200	-	-	100	230	450	900	1,500			
Emergency Stop Torque T_{2NOT}^2	Nm	1,2	3~200	3 times of nominal output torque						
Nominal Input Speed n_{1N}	rpm	1,2	3~200	5,000	5,000	4,000	4,000	3,000	3,000	2,000
Max. Input Speed n_{1B}	rpm	1,2	3~200	10,000	10,000	8,000	8,000	6,000	6,000	4,000
Backlash	arcmin	1	3~20	≤10	≤10	≤10	≤10	≤10	≤10	≤10
		2	25~200	≤14	≤14	≤14	≤14	≤14	≤14	≤14
Torsional Rigidity	Nm/arcmin	1,2	3~200	3	7	14	25	50	145	225
Max. radial load F_{2rB}^3	N	1,2	3~200	702	1,377	2,985	6,100	8,460	13,050	8,700
Max. axial load F_{2aB}^3	N	1,2	3~200	390	765	1,625	3,350	4,700	7,250	18,000
Service life	hr	1,2	3~200	20,000*						
Efficiency η	%	1	3~20	≥95%						
		2	25~200	≥92%						
Weight	kg	1	3~20	1.0	2.1	5.8	11.2	22.4	46.8	78.0
		2	25~200	1.3	2.0	4.6	11.1	21.8	43.7	81.9
Operating temp	°C	1,2	3~200	-10°C~90°C						
Lubrication				Synthetic lubrication oils						
Degree of gearbox protection		1,2	3~200	IP65						
Mounting position		1,2	3~200	all directions						
Noise Level ($n_1=3000\text{rpm}$, No Load)	dB(A)	1,2	3~200	≤61	≤63	≤65	≤68	≤70	≤72	≤74

Gearbox Inertia

Model No.	Stage	Ratio	AER050	AER070	AER090	AER120	AER155	AER205	AER235
Mass Moments of Inertia J_1	1	3~10	0.09	0.35	2.25	6.84	23.4	68.9	135.4
		14	-	0.07	1.87	6.25	21.8	65.6	119.8
		20	-	0.07	1.87	6.25	21.8	65.6	119.8
	2	15	0.09	-	-	-	-	-	-
		20	0.09	-	-	-	-	-	-
		25~100	0.09	0.09	0.35	2.25	6.84	23.4	68.9
120~200	-	-	0.31	1.87	6.25	21.8	65.6		

1. Ratio ($i=N_n/N_{out}$)

2. $T_{2B} = 60\%$ of T_{2NOT}

3. Applied to the output shaft center @ 100 rpm

★ S1 service life 10,000 hrs (Consult us)

AER Series

Dimensions (1-stage, Ratio $i=3\sim 20$)

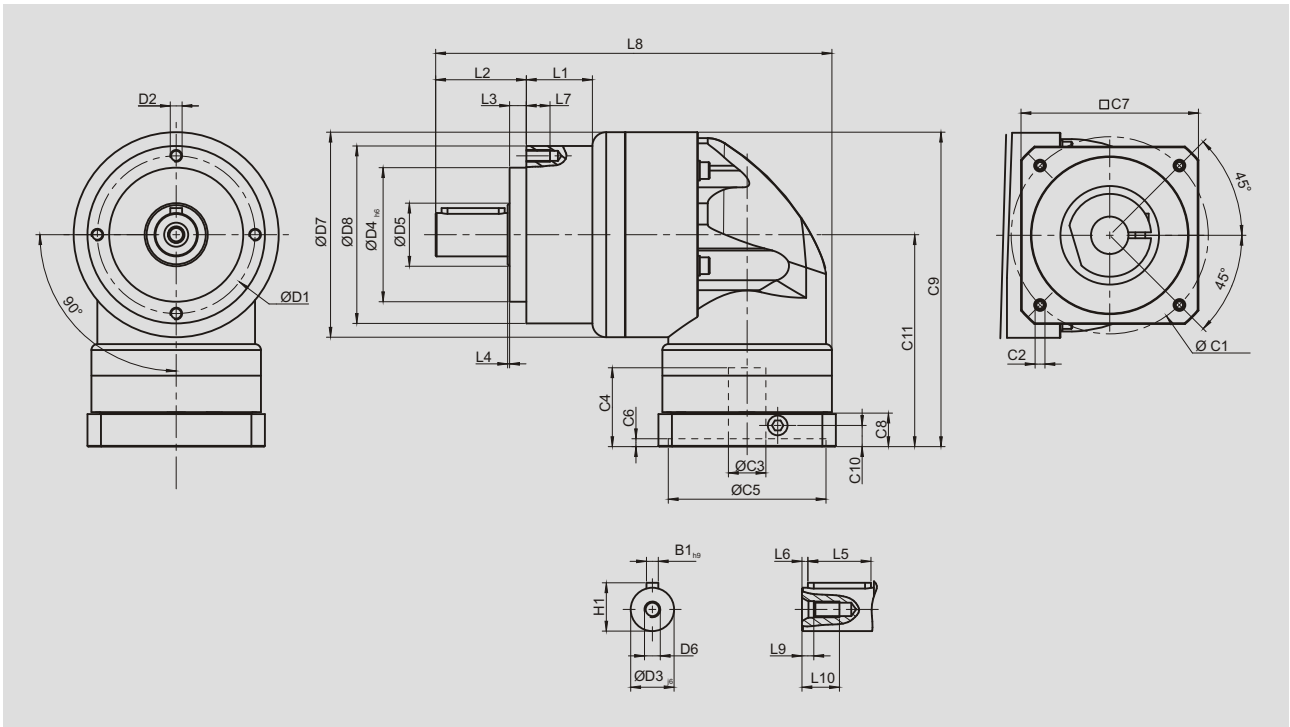

[unit: mm]

Dimension	AER050	AER070	AER090	AER120	AER155	AER205	AER235
D1	44	62	80	108	140	184	210
D2	M4 x 0.7P	M5 x 0.8P	M6 x 1P	M8 x 1.25P	M10 x 1.5P	M12 x 1.75P	M16 x 2P
D3 _{j6}	12	16	22	32	40	55	75
D4 _{h6}	35	52	68	90	120	160	180
D5	22	22	30	40	75	95	115
D6	M4 x 0.7P	M5 x 0.8P	M8 x 1.25P	M12 x 1.75P	M16 x 2P	M20 x 2.5P	M20 x 2.5P
D7	53	70	104	130	162	205	260
D8	50	70	90	120	155	205	235
L1	--	--	33.5	38	50	--	70
L2	24.5	36	46	70	97	100	126
L3	4	6.5	8.5	17.5	15	15	18
L4	1	1	1	1.5	3	3	3
L5	14	25	32	40	63	70	90
L6	2	2	3	5	5	6	7
L7	8	10	12	16	20	22	28
L8	115.5	146	201	252	324.5	379.5	461.5
L9	4.5	4.8	7.2	10	12	15	15
L10	10	12.5	19	28	36	42	42
C1 ⁴	46	70	100	130	165	215	235
C2 ⁴	M4 x 0.7P	M5 x 0.8P	M6 x 1P	M8 x 1.25P	M10 x 1.5P	M12 x 1.75P	M12 x 1.75P
C3 ⁴	≤11 / ≤12	≤14 / ≤16	≤19 / ≤24	≤32	≤38	≤48	≤55
C4 ⁴	30	34	40	50	60	85	116
C5 ⁴	30	50	80	110	130	180	200
C6 ⁴	3.5	8	4	5	6	6	6
C7 ⁴	48	60	90	115	142	190	220
C8 ⁴	19.5	19	17	19.5	22.5	29	63
C9 ⁴	100.5	116.5	159.5	199	245.5	316	398.5
C10 ⁴	13.25	13.5	10.75	13	15	20.75	53.5
C11 ⁴	74	81.5	107.5	134	164.5	213.5	268.5
B1 _{h9}	4	5	6	10	12	16	20
H1	14	18	24.5	35	43	59	79.5

4. C1~C11 are motor specific dimensions (metric std shown). Refer to Apexdyna.com and Design Tool to view your specific motor mounting system.

Dimensions (2-stage, Ratio i=25~200)

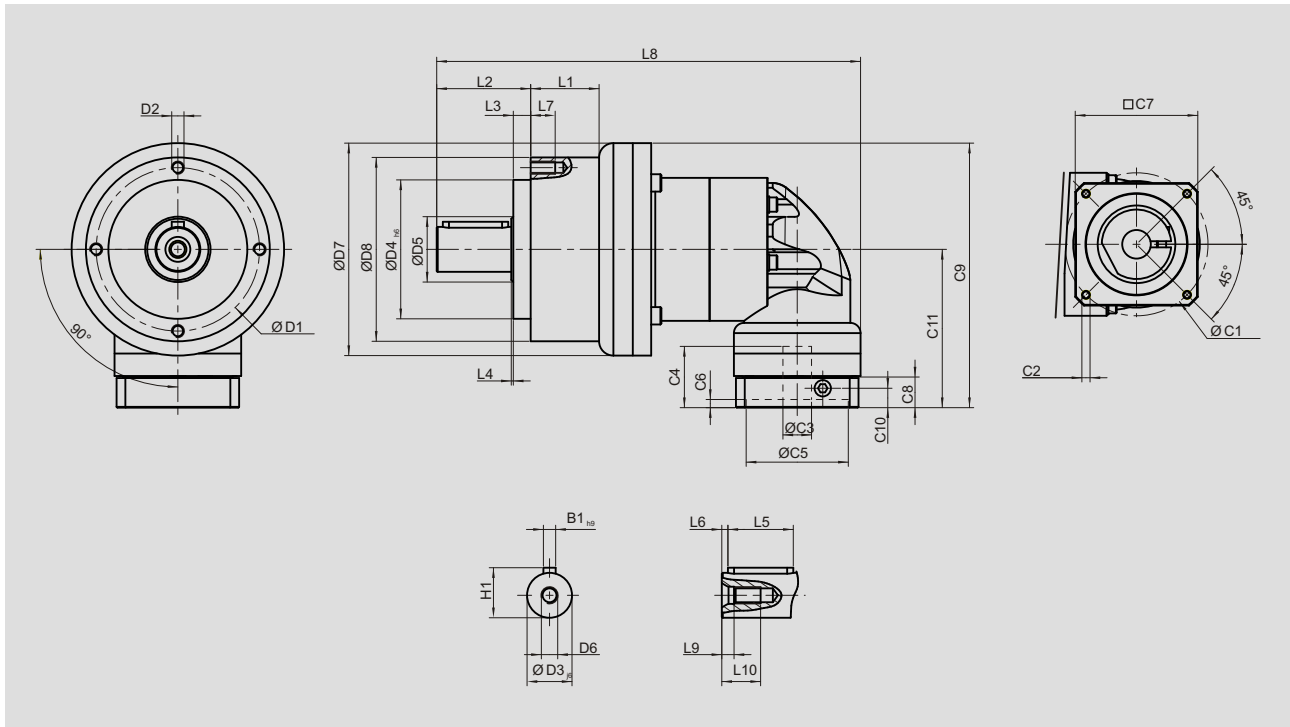

[unit: mm]

Dimension	AER050	AER070	AER090	AER120	AER155	AER205	AER235
D1	44	62	80	108	140	184	210
D2	M4 x 0.7P	M5 x 0.8P	M6 x 1P	M8 x 1.25P	M10 x 1.5P	M12 x 1.75P	M16 x 2P
D3 _{j6}	12	16	22	32	40	55	75
D4 _{h6}	35	52	68	90	120	160	180
D5	22	22	30	40	75	95	115
D6	M4 x 0.7P	M5 x 0.8P	M8 x 1.25P	M12 x 1.75P	M16 x 2P	M20 x 2.5P	M20 x 2.5P
D7	53	70	104	130	162	205	260
D8	50	70	90	120	155	205	235
L1	--	--	33.5	38	50	--	70
L2	24.5	36	46	70	97	100	126
L3	4	6.5	8.5	17.5	15	15	18
L4	1	1	1	1.5	3	3	3
L5	14	25	32	40	63	70	90
L6	2	2	3	5	5	6	7
L7	8	10	12	16	20	22	28
L8	142.5	167.5	207.5	283	358	422.5	506.5
L9	4.5	4.8	7.2	10	12	15	15
L10	10	12.5	19	28	36	42	42
C1 ⁵	46	46	70	100	130	165	215
C2 ⁵	M4 x 0.7P	M4 x 0.7P	M5 x 0.8P	M6 x 1P	M8 x 1.25P	M10 x 1.5P	M12 x 1.75P
C3 ⁵	≤11 / ≤12	≤11 / ≤12	≤14 / ≤15.875 / ≤16	≤19 / ≤24	≤32	≤38	≤48
C4 ⁵	30	30	34	40	50	60	85
C5 ⁵	30	30	50	80	110	130	180
C6 ⁵	3.5	3.5	8	4	5	6	6
C7 ⁵	48	48	60	90	115	142	190
C8 ⁵	19.5	19.5	19	17	19.5	22.5	29
C9 ⁵	100.5	109	133.5	172.5	215	267	343.5
C10 ⁵	13.25	13.25	13.5	10.75	13	15	20.75
C11 ⁵	74	74	81.5	107.5	134	164.5	213.5
B1 _{h9}	4	5	6	10	12	16	20
H1	14	18	24.5	35	43	59	79.5

5. C1~C11 are motor specific dimensions (metric std shown). Refer to Apexdyna.com and Design Tool to view your specific motor mounting system.

Output Dimensions

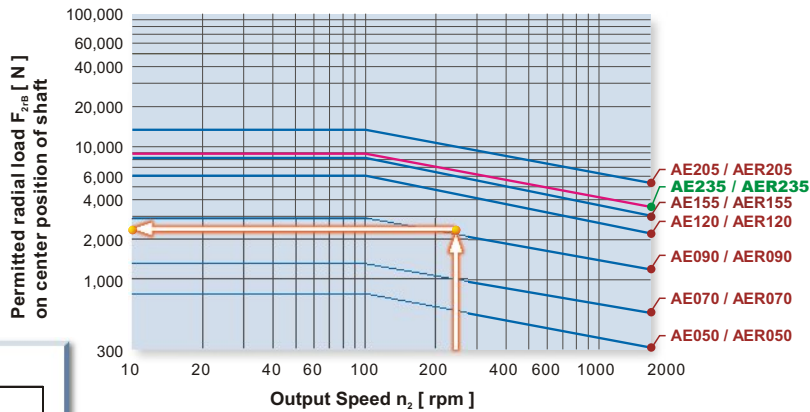

If radial force F_z exert on the center of the output shaft $X=1/2 \times L$. Under various operating condition the lifetime is over 20,000* hours. The permitted radial load is given on left diagram.

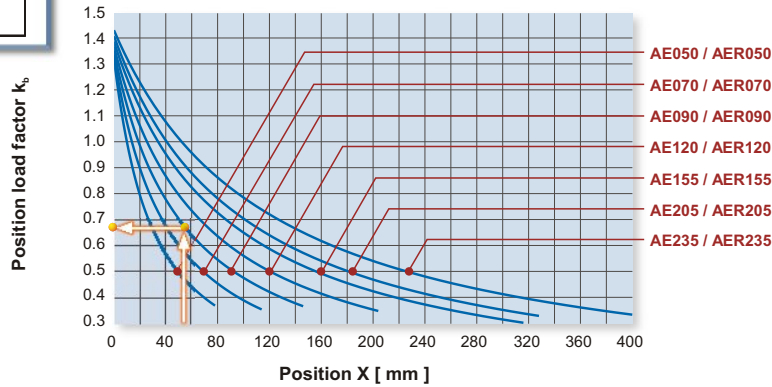
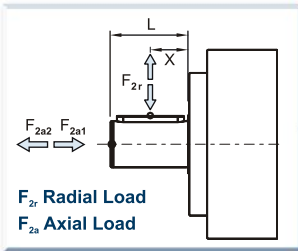

If radial force F_z not exert on the center of the output shaft $X < 1/2 \times L$ or $X > 1/2 \times L$. The permitted radial and axial load can be calculated by the position load factor k_b on the left diagram.

* Continuous running reduces service life by 50%

Front plate option

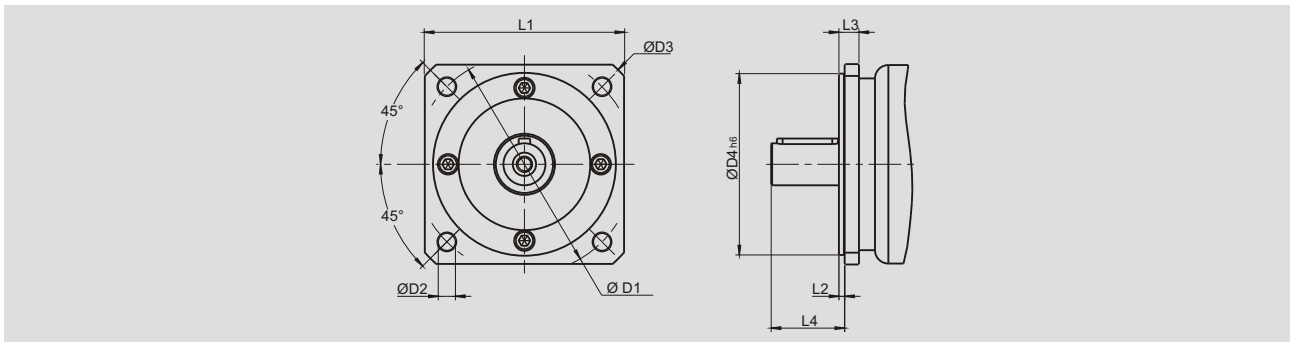

[unit: mm]

Dimension	D1	D2	D3	D4 ^{h6}	L1	L2	L3	L4
AE050(AER050)-NEMA 23	66.675	6	77	38.1	57.2	2	8	18.5
AE050(AER050)-PX60	70	5.6	80.5	50	60	2.5	8.5	18.5
AE070(AER070)-Metric	90	6.6	106	50	80	3	11	28
AE070(AER070)-NEMA 34	98.425	5.6	115	73.08	86	2.5	8	30.5
AE070(AER070)-DT90 / PX90	100	6.6	120	80	90	3	8	31
AE090(AER090)-IEC 63D5 B5	115	9	140	95	105	3	10.5	38.5
AE090(AER090)-NEMA 34	98.425	5.5	122	73.025	92	2.5	12.5	36
AE090(AER090)-DT90 / PX90	100	6.5	122	80	92	2.5	12.5	36
AE090(AER090)-NEMA 42	125.73	7	144	55.58	107	4	14.5	35.5
AE120(AER120)-NEMA 42	125.73	7.1	170	55.499	127	1.5	21.5	50
AE120(AER120)-NEMA 56	149.225	6.6	170	114.3	127	3	17.5	55.5
AE155(AER155)-B5	175	11	196	130	160	5	20	82
AE205(AER205)-B5	230	13	277	180	210	5	23	82
AE235(AER235)-B5	275	17	317	235	240	5	23	108

Ordering Code

AE Series

AE090

–

010

–

MOTOR

Gearbox Size:

AE050, AE070, AE090
AE120, AE155, AE205, AE235

Motor Designation:

Manufacturer Type
And Model

Ratio:

1 Stage: 3, 4, 5, 6, 7, 8, 9, 10
2 Stage: 15, 20, 25, 30, 35, 40, 45, 50, 60, 70, 80, 90, 100

Ordering Example: AE090-010 / SIEMENS 1FT6 041-4AF71

AER Series

AER050

–

010

–

MOTOR

Gearbox Size:

AER050, AER070, AER090
AER120, AER155, AER205, AER235

Motor Designation:

Manufacturer Type
And Model

Ratio:

1 Stage: 3, 4, 5, 6, 7, 8, 9, 10, 14, 20
2 Stage: 15, 20, 25, 30, 35, 40, 45, 50, 60, 70,
80, 90, 100, 120, 140, 160, 180, 200

Ordering Example: AER050-010 / SIEMENS 1FT5 034-OAK71

AE / AER Series

Planetary Gearboxes
High Precision
High Speed

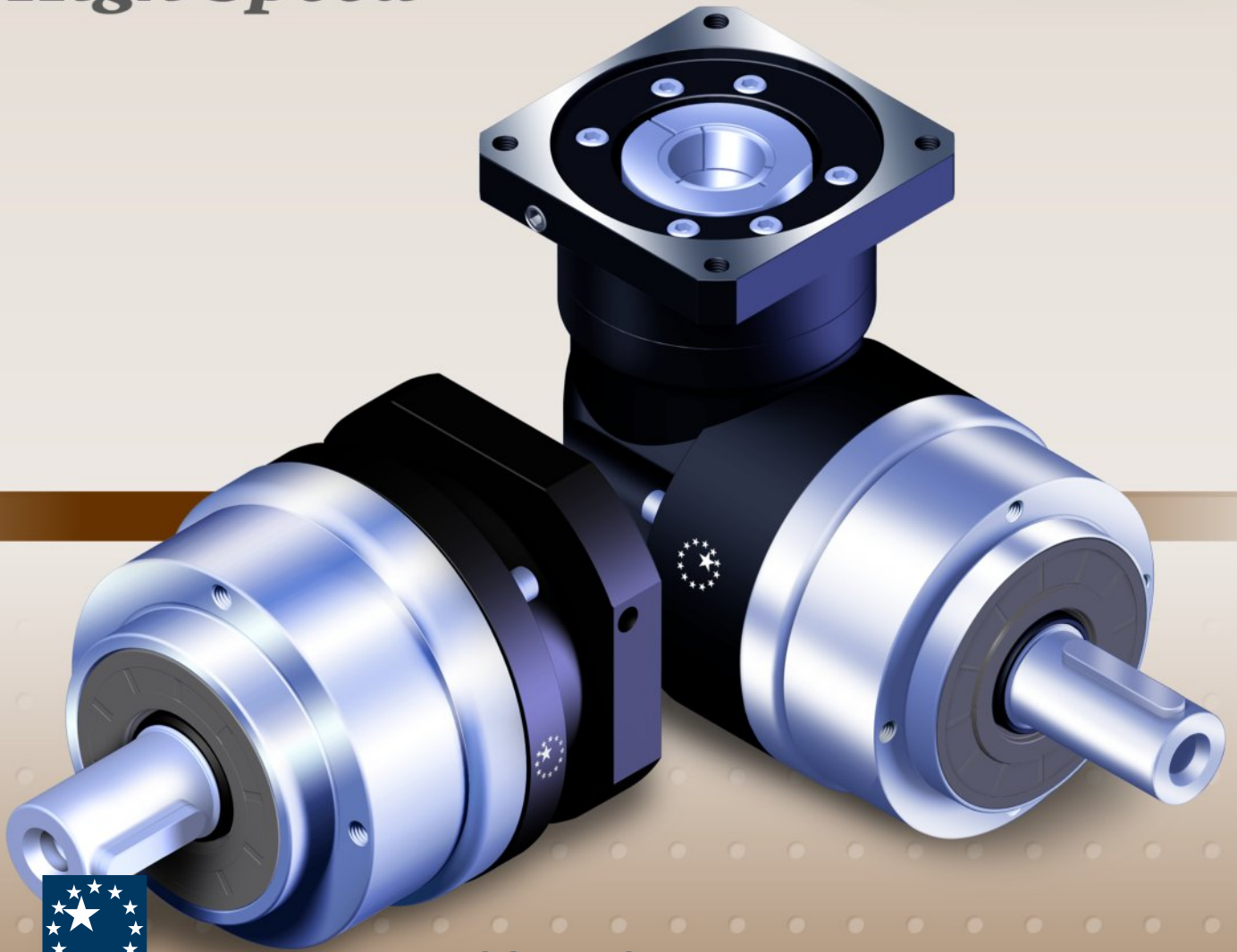

APEX DYNAMICS, INC.

